



FUEL MANAGEMENT
SYSTEMS



DISPENSERS



KITS



POMPE



CONTALIBRI



PISTOLE

E80 / E120

CARATTERISTICHE

- VERSATILITÀ
- STRUTTURA ROBUSTA
- LUNGA DURATA
- PRONTO ALL'USO
- PROTEZIONE TERMICA

PIUSI E80 e E120 sono elettropompe rotative a palette autoadescenti, compatte e facili da installare, adatte a soddisfare tutte quelle esigenze di utilizzo che richiedono un prodotto ad alte prestazioni e di lunga durata. La struttura robusta, la protezione termica e i componenti di alta qualità ne consentono l'utilizzo a basse temperature di esercizio.

PERFORMANCE

FINO A

100 L/MIN

PORTATA

FUNZIONAMENTO

AC
CONTINUO

POTENZA



E80/E120

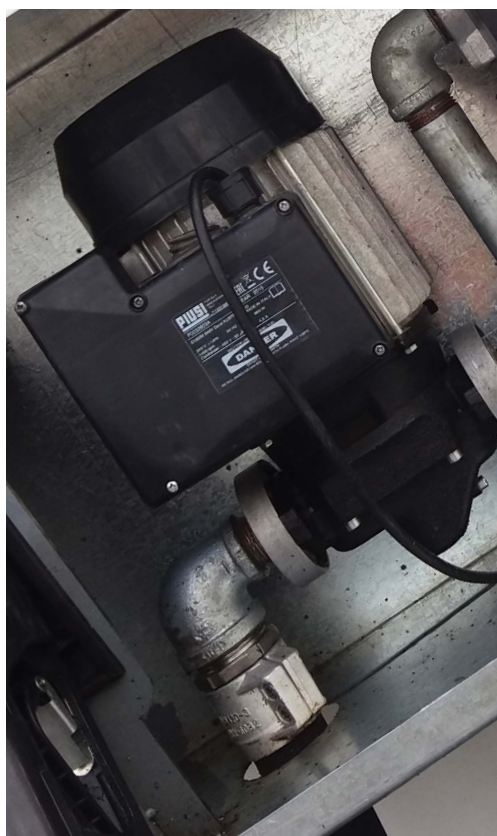

PACKAGING

CODICE	PESO		PACKAGING			N. BOX / EUROPALET	
	KG	LBS	MM	INCH	PCS/BOX	✈	🚚
E80							
000305000	10,26	22,6	355X185X285	-	1	60	72
000307000	10,26	22,6	355X185X285	-	1	60	72
E120							
000326000	13,25	29,2	355X185X285	-	1	60	72
000312000	13,25	29,2	355X185X285	-	1	60	72



FILTRAZIONE



MONITORAGGIO FLUIDI



ARROTOLATORI



ACCESSORI



MERCHANDISE



ARIA



ANTIGELO



AdBlue®



BIODIESEL



DIESEL



ALIMENTI



BENZINA



GRASSO



KEROSENE



OLIO



ACQUA



LAVAVETRI

GRAFICO

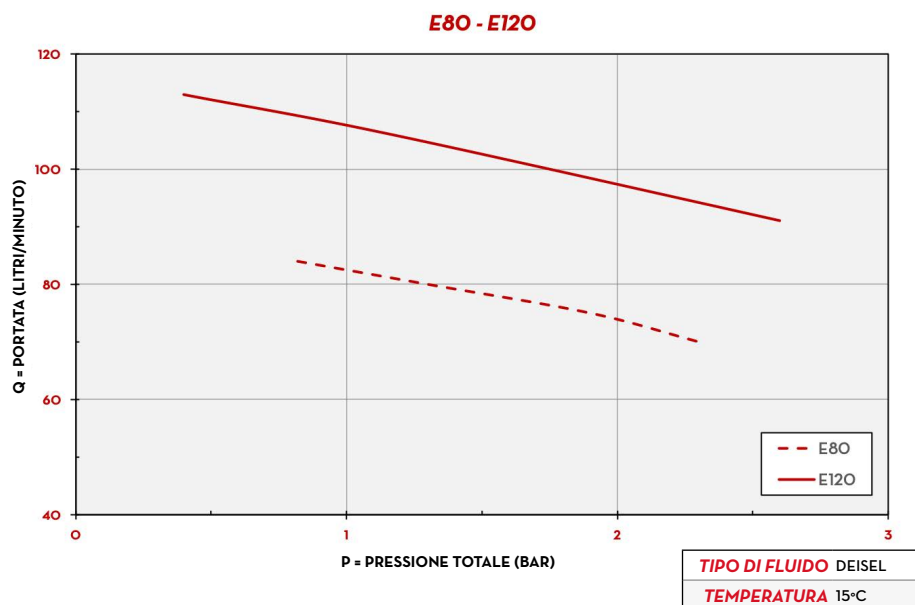

DENTRO LA SCATOLA

- POMPA E80/E120
- COLLEGAMENTO FLANGIATO
- MANUALE ISTRUZIONI

DETTAGLI



ROTORE A PALETTE



FLANGED CONNECTION

DIMENSIONI

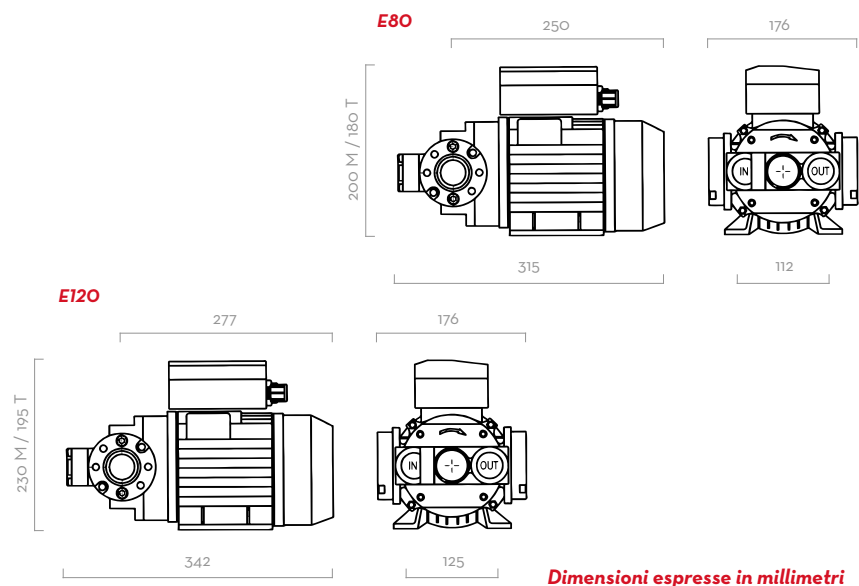

MATERIALI

- CORPO: GHISA
- ROTORE: ACCIAIO SINTERIZZATO
- PALETTE: RESINA ACETALICA
- GUARNIZIONE: VITON
- ALBERO: ACCIAIO



POMPA

- MASSIMO 6M (20FT),
- TUBO DI ASPIRAZIONE Ø 1" MIN,
- MASSIMA ALTEZZA D'ASPIRAZIONE:
 - 2M (7FT) SENZA VALVOLA DI NON RITORNO
 - 4M (14FT) CON VALVOLA DI NON RITORNO



FUSTO

DATI TECNICI

CODICE	DESCRIZIONE	TIPO DI FLUIDO	PORTATA		VOLTAGGIO				RPM	INGRESSO OUTLET BSP	CONNESSIONI FLANGIATE	VALVOLA DI BYPASS	INGRESSO FILTER
			L/MIN	GPM	SINGLEPHASE MOTOR V/Hz	THREEPHASE MOTOR V/Hz	POTENZA WATT	AMP. MAX.					
E 80													
000305000	E 80 M	D	70	18	230/50	-	500	3,5	1400	1"	SI	SI	NO
000307000	E 80 T	D	70	18	-	400/50	550	1,6	1450	1"	SI	SI	NO
E 120													
000326000	E 120 M	D	100	26	230/50	-	750	5,7	1450	1"	SI	SI	NO
000312000	E 120 T	D	100	26	-	400/50	750	2,2	1450	1"	SI	SI	NO

E80 / E120